

RAPIDCUT - 16

DIMENSIONES GENERALES:

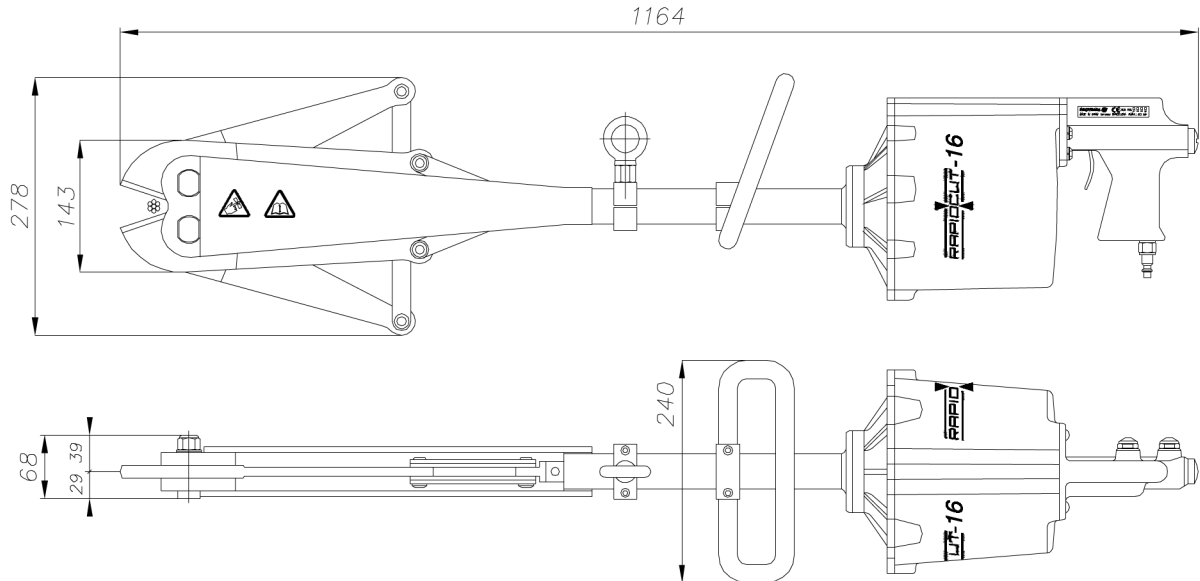

CARACTERISTICAS TECNICAS:

ALIMENTACION.....Aire comprimido filtrado y lubricado

CONSUMO.....48 Lt./corte a 7 bar

Ø MÁXIMO: 16Ø (Acero de hasta 70 Kg./mm²) Con las cuchillas REF: 1660J

 7 x 5Ø (acero de hasta 180 Kg./mm²) Con las cuchillas REF: 1680R

VELOCIDAD.....10 Cortes/minuto

PRESION MAXIMA.....8.5 bar

PRESION MINIMA.....6 bar

PESO.....18 Kg.

CUCHILLAS MAS APROPIADAS:

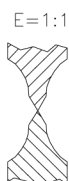
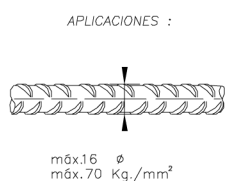

CUCHILLAS MAS APROPIADAS :

