

# RAPIIDCUT -6

## CARACTERISTICAS TECNICAS

ALIMENTACION.....Aire comprimido filtrado y lubricado  
 CONSUMO.....3.78 Lt./corte a 6.5 bar  
 Ø MÁXIMO A CORTAR.....6Ø (Acero de hasta 70 Kg./mm<sup>2</sup>)  
 4Ø (Acero de hasta 180 Kg./mm<sup>2</sup>)  
 VELOCIDAD.....60 Cortes/minuto  
 PRESION MAXIMA.....8.5 bar  
 PRESION MINIMA.....6 bar  
 PESO.....3.2 Kg.

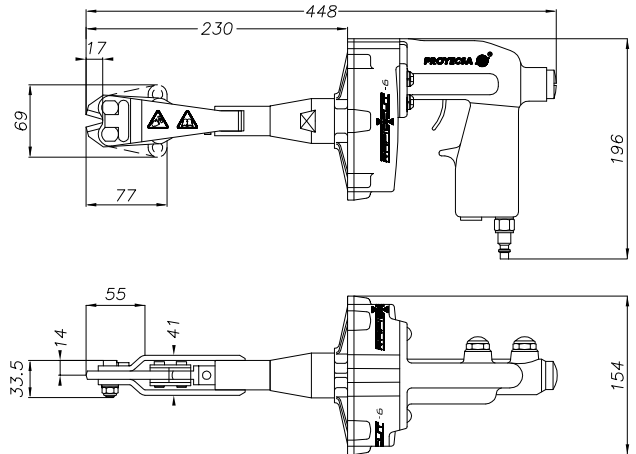

# RAPIIDCUT -6L

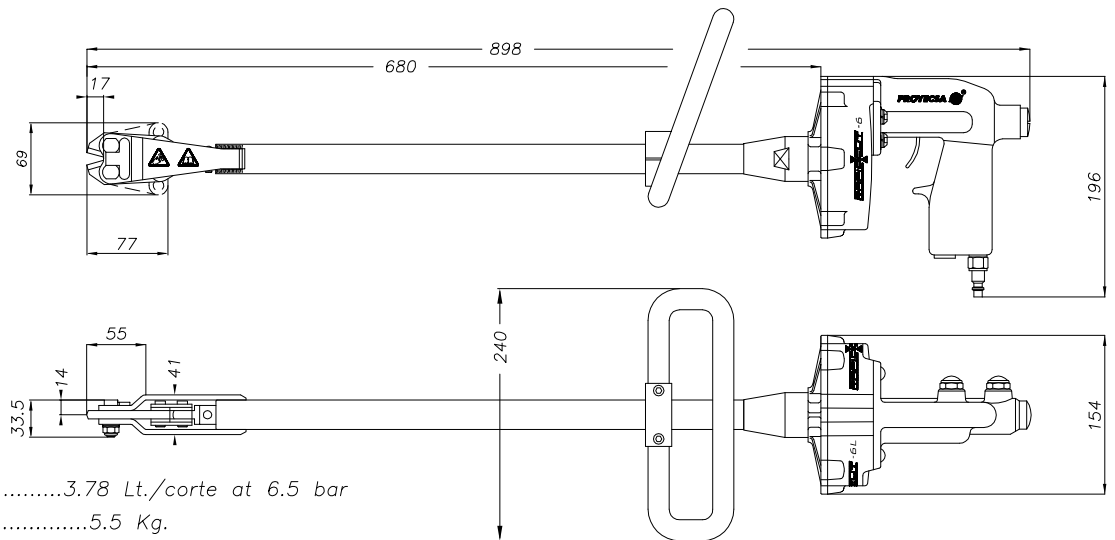

CONSUMO.....3.78 Lt./corte at 6.5 bar  
 PESO.....5.5 Kg.

## CUCHILLAS MAS APROPIADAS

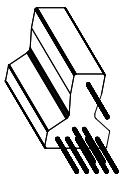

MAX. 4Ø  
 ref. C80LAP  
 Alambre para pretensados  
 Hasta 180 Kg./mm<sup>2</sup>

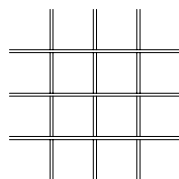

MAX. 6Ø  
 ref. C80LAP  
 Acero corrugado  
 Hasta 70 Kg./mm<sup>2</sup>